

# STC 361 - 1300



**Hydraulic grinding  
milling machine for cylinder heads and blocks**

A Company  
of ThyssenKrupp  
Technologies

**BERCO** S.p.A.



# The machine and its executions

- from grinding wheel to tool: 1'  
- from tool to milling cutter: 3'  
These are the tool changeover times required to pass from one machining method to another.



General view of the standard machine version.

General view of the machine with sliding doors protection in accordance to "CE" regulation. Inset





The **STC 361** is the range of hydraulic grinding/milling machines for the reconditioning of mating surfaces on small and medium sized cylinder heads and blocks which Berco, who supply machine tools in this sector worldwide, are now making available to users. Compared to the previous very popular range of grinding/milling machines, the **STC 361** series offers greater reliability, even further improved operating precision and more practical, safer operation.

The **STC 361** range are simple, versatile machines able to meet the requirements of large and small workshops alike, since they provide an excellent, economical solution to all grinding/milling problems. They can operate: with segmental wheel for grinding materials of all kinds; with single-point tool for cutting aluminium and, on request, with a multi-edged insert milling cutter for rapid cutting of cast iron and aluminium. The special feature of the **STC 361** machines is the automatic, hydraulically powered alternating table traverse. They are available with table working traverse 1300 mm (51"), and can be ordered in

versions "C-E" which vary, as explained forward, in component assemblies and operating procedures. A few features of this new line of grinding and milling machines:

**Controls.** These are all on the front of the machine, conveniently positioned for checks and handling. Table. Runs on automatically lubricated flat and V-shaped ways. Controlled by a lever for manual and automatic reverse and a knob providing the STOP function and traverse speed selection. The table runs without "stick-slip" problems even at very low speeds.

**Wheelhead.** Driven by a high powered main motor driving the wheel holder shaft directly, an auxiliary motor for the milling cutter and a handwheel with adjustable graded ring for controlled cutting depth setting.

**Cooling system.** The coolant tank, separate from the machine, is complete with wheels for easy transfer to the emptying, cleaning and filling site.

**Electrics.** Complete with main switch fitted for padlocking, emergency pushbutton and devices providing protection against power failure.



#### **Resurfacing methods.**

Depending on the material and the level of finishing required, there are three different machining procedures available: using grinding wheel, single-point cutter and multi-edged insert milling cutter. It takes just a few minutes to change from one system to another, since both the single-point cutter and the milling cutter are mounted directly on the wheel holder ring.

**Accessories.** For economic, accurate grinding and milling of normal and V-type cylinder heads and blocks, various types of fixture are available. Other machining possibilities are opened up by the use of a power-driven rotary table which, combined with a flaring cup wheel and its hub, allows reconditioning of the recesses or protrusions on flywheels, clutch pressure plates, brake discs etc.

**Top: wheelhead for operation with abrasive segments, cutting tool and milling cutter. Change-over of the various tools is very quick and easy.**



**Grinding a cylinder block with segmental wheel.**

**Version C**

Machine with 2 spindle shaft rotation speeds for processing with segmental grinding wheel and single-point tool, and with power-driven head traverse.

**Version E**

Machine having the same technical features and applications as version "C" with adjustable automatic head feed at each return table traverse, and 3 spindle shaft rotation.

All the versions are available with variable spindle speed.

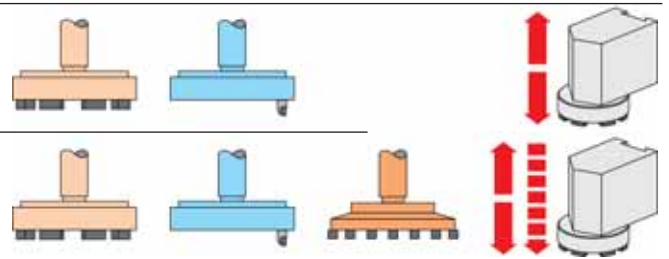

**Fig. 1**  
Reconditioning of manifold mating surfaces with insert type milling tool. The head is clamped on the universal square.



**Fig. 2**  
Milling a cylinder head using insert type milling cutter.



# Items available for the machine

Fig. 3



Fig. 4



Fig. 3

Resurfacing a cylinder head with cutting tool. The head is clamped on the parallel supports.

Fig. 4

Alignment and surface straightness check device.

Fig. 5

Adjustable setup fixture for cylinder heads.

Fig. 5



## STANDARD OUTFIT

- Set of splash guards.
- Coolant system complete with electric pump and coolant tank.
- Segmental wheel holder plate 360 mm dia. ( $14\frac{3}{16}$ "") complete with balance weights and 10 grinding segments for use on cast iron (part number U820519001).
- Tool with brazed tip for resurfacing aluminium alloy cylinder heads (part number U202266022).
- Segmental wheel holder extractor tool (part number A00A31808).
- Wheel balancing arbor (part number A00A31809).
- Wheel dresser (complete with toothed wheels part number C465800000).

- 2 parallel supports, size 135x440 mm ( $5\frac{5}{16}$  x  $17\frac{11}{16}$ "").
- 2 slanting blocks for mounting on parallel supports, for cylinder head clamping (fig. 3).
- Set of screws, nuts, fixing brackets and service spanners.

## EXTRA OUTFIT

- **U820519001**  
Abrasive segment for cast iron.
- **U820022001**  
Abrasive segment for steel, cast iron and for aluminium heads with steel precombustion chambers.
- **A00A31459**  
Diamond holder arm, for dressing segmental wheel (without diamond).

- **C465904010**  
1.5 K diamond for diamond holder arm, for dressing segmental and flaring cup wheels.
- **A00A02680**  
Insert holder for resurfacing, without insert (fig.1).
- **U003158030**  
Insert for aluminium.
- **V05A31004**  
Safety guard according to "CE" regulations.
- **A00A31670**  
Milling cutter 300 mm dia. ( $11\frac{13}{16}$ "") complete with 8 inserts part No. U003355020 For cast iron and aluminium (for version "E" only).
- **A00A31736**  
Milling cutter 406 mm (16")dia., with guard.
- **A00.46843C**  
Tool grinder for tools with brazed tool tip (without grinding wheel and tool grinding jig).
- **A00.67506**  
Diamond wheel for tool grinder.
- **A00A02647**  
Tool-grinding jig.
- **A00A31650**  
Surface straightness check, without dial indicator (fig. 4).

- **A00.51319**  
Dial indicator, metric.
- **A00.51320**  
Dial indicator, in inches.
- **A00A02609**  
Spirit level with V-shape base.
- **A00.61200C**  
Static balancer for segment holder wheel (AES 500).
- **A00A31804**  
Parallel support 80x440 mm ( $3\frac{5}{32}$ " x  $17\frac{11}{16}$ "").
- **V08A31005**  
Assembled magnetic coolant clarifier unit complete with suitable tank, which replaces the standard one.

Fig. 6



Fig. 7



Figs. 6-7  
Rotary table used for grinding the recesses of a flywheel and a clutch plate.

Fig. 8  
Grinding some mechanical components with permanent magnet chuck.

Fig. 9  
Adjustable setup fixture for V-blocks.

Fig. 8



Fig. 9



### Cylinder head and block setup fixtures

- **A01.32433**  
Adjustable setup fixture for clamping V-type cylinder heads and blocks (figs.5-8).
- **A00.41731A**  
Universal cylinder head setup square (fig. 1).
- **A00A02600**  
Parallel support for cylinder heads complete with plate and lock screws (2 pieces required) (fig. 2).
- Other setup fixtures available on request.

### Special processing accessories

- **P02A31700**  
Power-driven rotary table (TR 1) for grinding flywheels, clutch pressure plates and brake discs (12 rpm - 0.2 kW) (figs.6-7).
- **A00A25651**  
Tooling for centering and clamping clutch pressure plates with diaphragm type springs onto the rotary table.
- **A00A25652**  
Set of screws and plates for clamping brake discs and flywheels onto the rotary table.

- **A00A31692**  
Wheel holder complete with flaring cup wheel for cast iron (part No. U814511020) 127 dia.x36x64 mm (5"x1<sup>13</sup>/<sub>32</sub>"x2<sup>17</sup>/<sub>32</sub>" ) for use with rotary table.
- **U814111101**  
Flaring cup wheel for steel 127 dia.x36 x64 mm (5"x1<sup>13</sup>/<sub>32</sub>"x2<sup>17</sup>/<sub>32</sub>" ).
- **A00A31691**  
Diamond holder arm for dressing flaring cup wheel (without diamond).

- **C150710020**  
Magnetic chuck 500x250 mm (19 1/16"x9 27/32").
- **C150710000**  
Magnetic chuck 610x250 mm (24"x9 27/32") (fig.9).
- **C150710010**  
Magnetic chuck 800x300 mm (31 1/2"x11 13/16").

All setup fixtures and accessories are supplied as extra outfit.

# Technical data

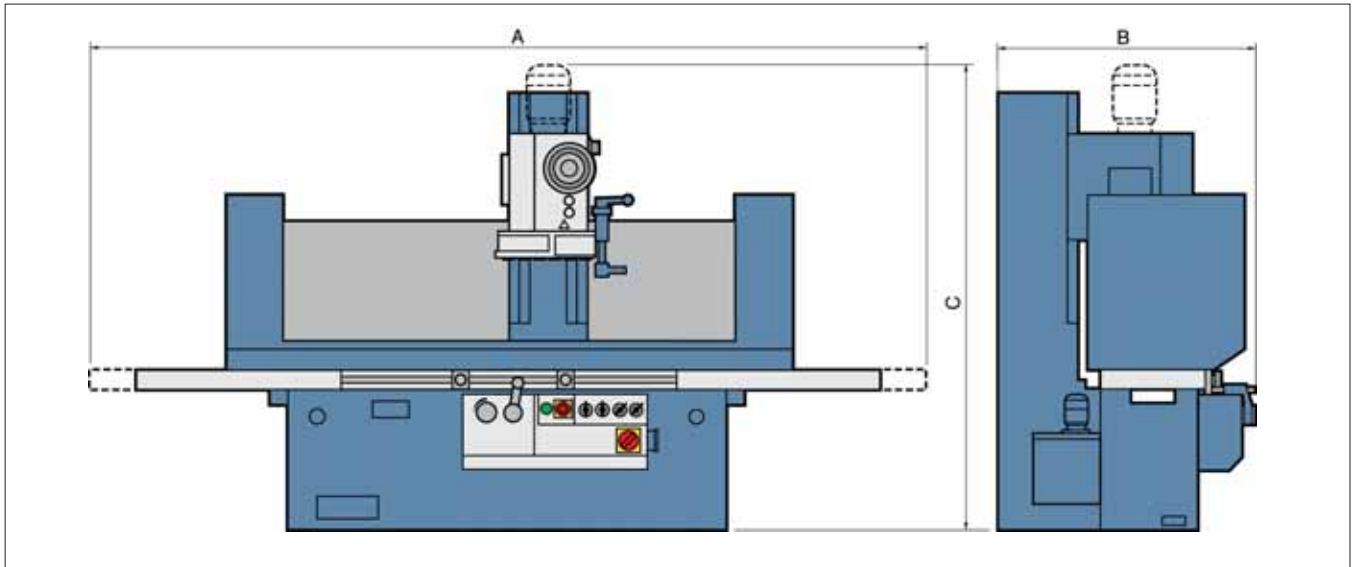

## Operating capacity

Max. automatic table traverse	mm	1300	(51")
Vertical wheelhead traverse	mm	680	(263/4")
Max. grinding width	mm	350	(133/4")
Max. grinding length on wide surface 280 mm (11")	mm	1200	(47")
Max. milling width with cutting tool	mm	330	(13")

## Geometric features

Useful table surface	mm	1220x280	(48x11")
Min. and max. height table to wheel	mm	0-700	(0-279/16")
Min. and max. height table to tool or milling cutter	mm	0-670	(0-263/8")
Distance from column to table C/L	mm	280	(11")
Segmental wheel diameter	mm	360	(143/16")
Multi-edged insert milling cutter diameter (version "E" only)	mm	300	(1113/16")

## Speeds and feeds

Spindle rotation speeds (2)	rpm	1400 and 700	
Spindle rotation speeds (stepless) "VS" version	rpm	200÷1900	
Milling rotating speed (version "E" only)	rpm	140	
Rapid wheelhead feed speed	mm/min.	660	(26")
Min. and max. table traverse feed speed (stepless),	mm/min.	100-4000	(4"-157")

## Motor ratings

Grinding and single-point cutting tool spindle	kW	3.6/0.6	(5/0.8 HP)
Milling cutter spindle (version "E" only)	kW	0.55	(0.75 HP)
Rapid vertical wheelhead traverse (versions "C" - "E" only)	kW	0.24	(0.33 HP)
Hydraulic system	kW	0.37	(0.5 HP)
Electric coolant pump	kW	0.09	(0.12 HP)

## Dimensions and weights

Length A	mm	4500	(177")
Width B	mm	970	(38")
Height C	mm	2160	(85")
Approx. weight, unpacked	kg	1220	(2690 lb)
Approx. weight, ocean packed	kg	1610	(3564 lb)

Motor rating is referred to 50 Hz frequency. Measurements, weights and executions are not binding on manufacturers and can be changed without previous notice.

**BERCO** S.p.A.  
Via 1° Maggio, 237  
44034 Copparo (FE) Italy  
Phone +39 0532 864 111  
Fax +39 0532 864 259  
www.berco.com  
machinetools@berco.com



00804.WM109GB00B



ISO 9001 Cert. n. 0029/4



ISO 14001 Cert. n. 0009A/2



Published by Berco Communications Dept.

All manufacturers's names, numbers, symbols and descriptions are used for reference purposes only. All parts listed are of Berco original production. The specifications and processes described in this brochure are subject to change without notice