

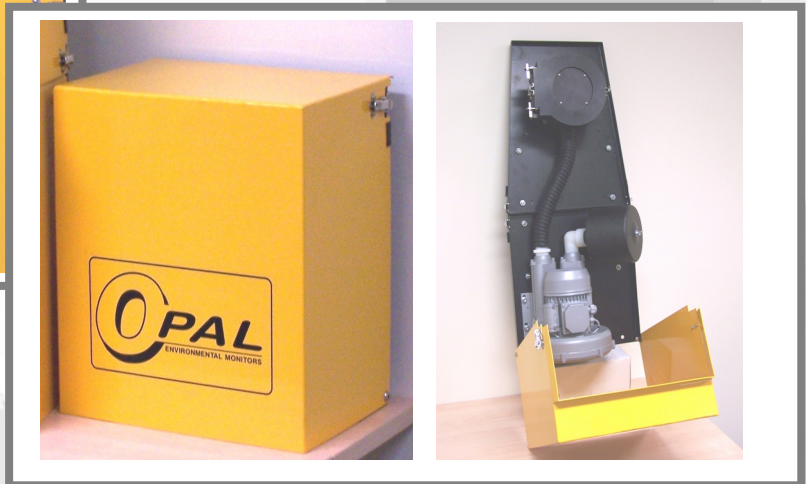

# OPAL 100 & 200 Air Blower Assemblies



- Wall mount & integrated assembly designs
- Single or dual side operation



- **Lightweight design with heavy duty filter & pre-cleaner**
- **Suitable for OPAL 100 and OPAL 200 application**
- **Kit includes air hose & couplings**
- **Variety of single & three phase supply options**

## 100 / 200AB Series - Technical Specifications

### OPAL-ABI

Enclosure  
Weight  
Mounting  
Access  
Power Supply  
Airflow

Designed for integration with OPAL 200 weather cover system, IP44 – rain proof  
18.5 Kg  
Below transceiver and retro mounting plates, using support brackets as supplied.  
Hinged front cover - release clips, swing down  
Standard 120 or 240vac, 50/60Hz, 6 ampere  
73 cubic metres per hour @ 1013 mbar

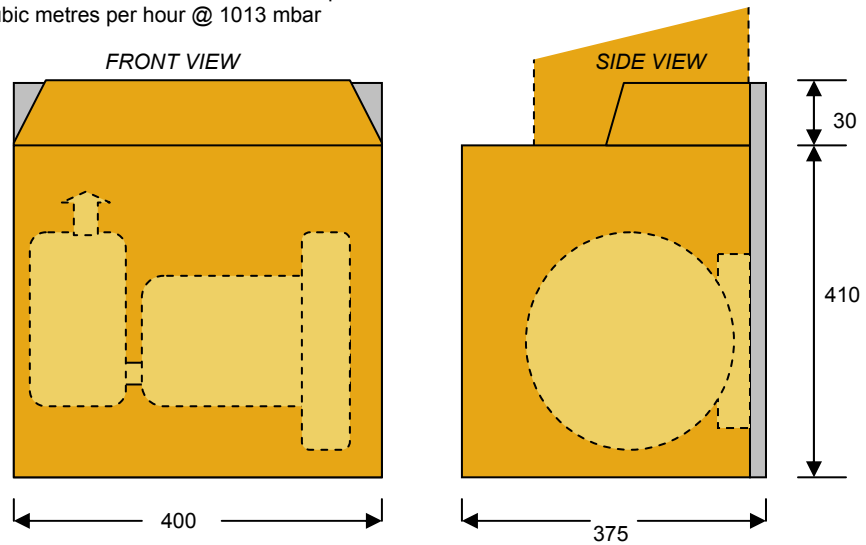

### OPAL-ABW

Enclosure  
Weight  
Mounting  
Access  
Power Supply  
Airflow  
Hose system

Wall mount type, IP44 – rain proof  
19.4 Kg  
Wall mount, via mounting straps (supplied). Hole centres 295W x 540H  
Hinged front cover - release clips, swing down  
Standard 120 or 240vac, 50/60Hz, 6 ampere  
73 cubic metres per hour @ 1013mbar  
OPAL 100 – 6 metre x 32mm hose      OPAL 200 – 6 metre x 38mm hose

