

# CHM 350 A

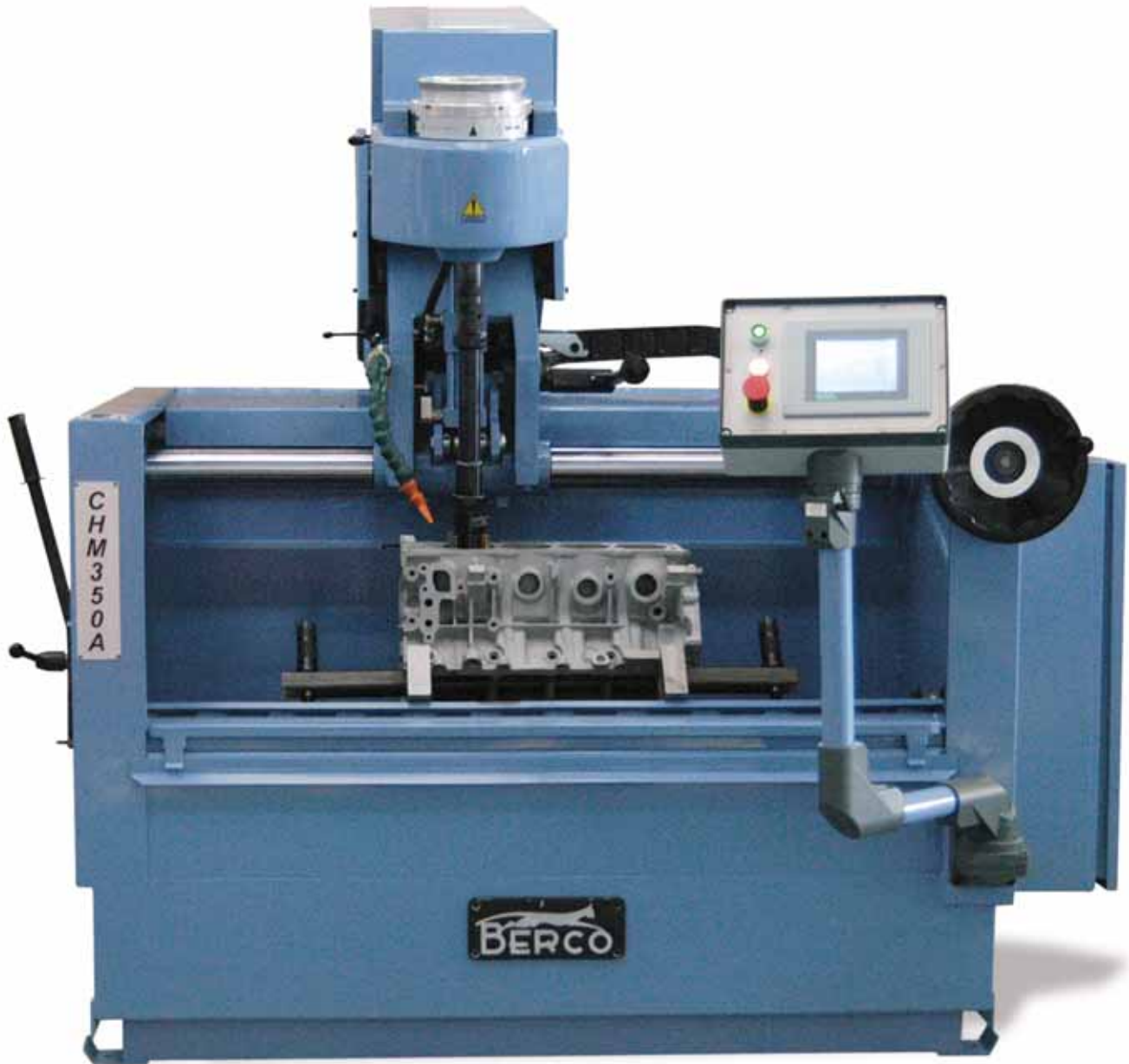

**Numerically controlled cylinder honing machine**

A Company  
of ThyssenKrupp  
Technologies

**BERCO S.p.A.**



# Numerically controlled cylinder honing machine

Following the success achieved on world markets with the traditional D31, D33, DY35, DY 600 and DY350 A Berco honing machines, with sales of these machines totalling over 5000, Berco has decided to resolve the present-day needs of operators in the industry with the creation of a renewed CNC honing machine capable

of the fully automatic management the honing process.

The machining cycle is managed by controlling a number of different parameters:

- a) regulation of honer stroke
- b) automatic expansion of honer
- c) setting honing crossover

- d) automatic control of bore geometry with enabling of correction cycle in automatic mode
- e) instantaneous display of all work parameters on touch screen control panel

- f) work cycle programming with self-learning procedure.

## Kits supplied

### NORMAL KIT

- 1 reference bar, length 900mm (351/2").
- 1 reference bar, length 1300mm (513/16").
- 1 handwheel for locking reference bar.
- parallel support, overturning, height 38/105mm (11/2" and 41/8") - 2 parts.
- 1 lubrication syringe.
- set of wrenches.

### ADDITIONAL EQUIPMENT

#### HONING HEADS

- **A00A33800**  
TL40 honing head, capacity 40 ÷ 60mm (137/64" - 23/8"), complete with shims for capacity check, guide shoes and stone carriers with abrasive stones (SG grade) installed.
- **A00A33820**  
TL 58 honing head, capacity 58 ÷ 86mm (29/32" - 33/8"), complete with shims for capacity check, guide shoes, stone carriers and abrasive stones (SG grade) with block.

- **A00A33860**  
TL 84 honing head, capacity 84 ÷ 127mm (35/16" - 5" ) (up to 155mm, 67/64" - with kit supplied separately), complete with shims for capacity check, guide shoes, stone carriers and abrasive stones (SG grade) with block.
- **A02A33860**  
Special kits for honing capacity from 127 to 155mm (5" - 67/64"), for honing head TL 84.
- **A00A33760**  
Bear for installing and removing abrasive stones with block (for TL58 and TL84).
- **A00A33780**  
Setting caliper for honing heads, capacity 58 - 155mm (29/32" - 67/64").

data sheet.

### OTHER ACCESSORIES

- **V08A33002**  
Coolant system with cartridge filter (to be ordered together with machine).
- **A00A33902**  
Tool bracket.
- **A00.56934**  
Motorcycle cylinder clamping fixture.
- **A03.20456**  
Quick clamping fixture for in-line cylinders (2 parts required).
- **A99.51283**  
AM 80 bore check gauge, capacity from 35 to 80mm (13/8" - 33/8").
- **A99.51322**  
AM 151 bore check gauge, capacity from 50 to 150mm (2" - 57/8").
- **A99.51362**  
AM 250 bore check gauge, capacity from 100 to 250mm. (3<sup>15</sup>/<sub>16</sub>" - 9<sup>7</sup>/<sub>8</sub>").
- **A00A33914**  
Support for bore check gauges.

"Touch screen" Control Panel



N.B.

As well as SG (cast iron roughing) abrasive, LG (cast iron finishing), SA (steel roughing) and LA (steel finishing) abrasives can also be supplied.

For more details on honing heads and accessories or spare parts, refer to specific

# Technical data

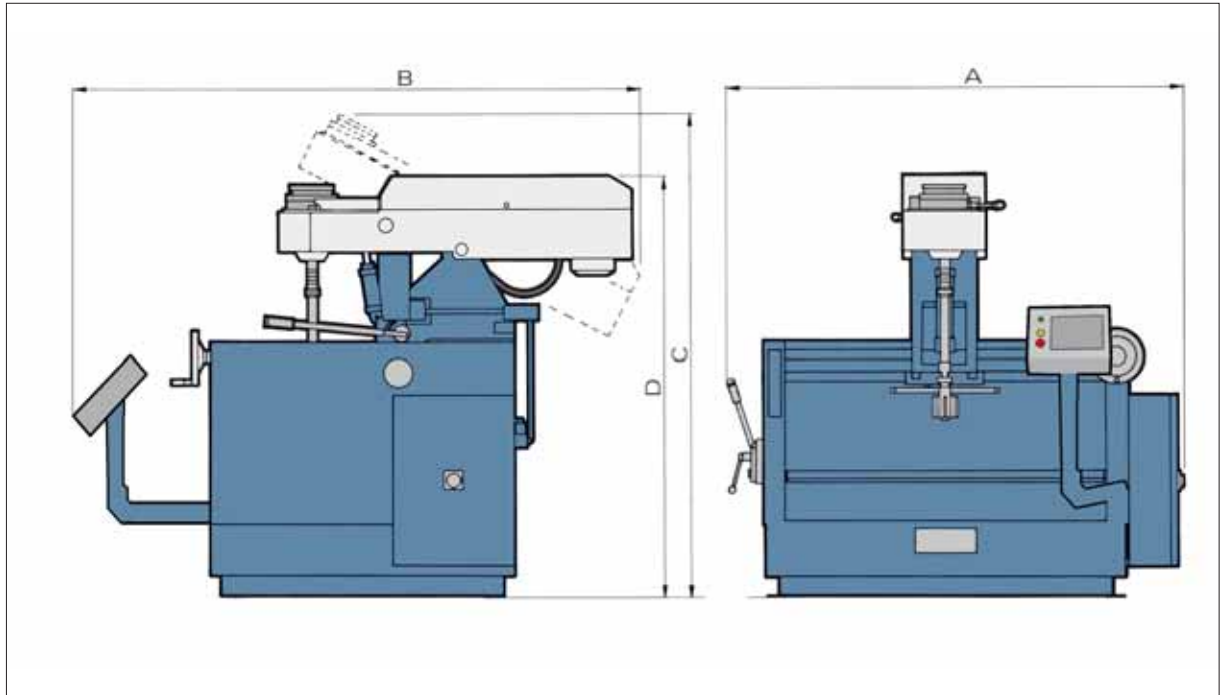

## units

### Machining capacity

Maximum honeable diameter	mm (inches)	203 (8")
Minimum honeable diameter	mm (inches)	40 (1,58")
Maximum honeable length	mm (inches)	350 (13,78")
Honer maximum alternative stroke	mm (inches)	280 (11")
Maximum permitted cylinder block length	mm (inches)	1200 (47")

### Speed and feed data

Spindle rotation speed, continuously adjustable	rpm	65 ÷ 300
Spindle traverse speed, continuously adjustable	m/min (inches/min)	0 ÷ 20 (0" - 787")
Maximum table tilting	degrees	± 45
Maximum lengthwise head movement	mm (inches)	1030 (40,55")

### Motor power

Honer rotation motor	kW/CV	2,2 - 3
Hydraulic motor	kW/CV	7,5 - 10
Coolant system electric pump	kW/CV	0,53 - 0,7

### Tank capacity

Coolant tank	litres - US gal.	200 - 52
Hydraulic system tank	litres - US gal.	70 - 19

### Dimensions

Length	mm (inches)	1900 (74,8")
Width	mm (inches)	2350 (95,5")
Height	mm (inches)	2000 (78,74")
Height and horizontal head (D)	mm (inches)	1800 (70,86")

### Weights

Approx. weight with normal kit, without packaging	kg (lbs)	950 (2100)
Approx. weight with normal kit, with shipping packaging	kg (lbs)	1280 (2820)

Measurements, weights and versions not binding, with right reserved to make modifications. Motor power data intended for frequency of 50 Hz.

**BERCO** S.p.A.  
Via 1° Maggio, 237  
44034 Copparo (FE) Italy  
Phone +39 0532 864 111  
Fax +39 0532 864 259  
www.berco.com  
machinetools@berco.com

00709.WM204GB00A

Published by Berco Communication Dept.



All manufacturers's names, numbers, symbols and descriptions are used for reference purposes only. All parts listed are of Berco original production. The specifications and processes described in this brochure are subject to change without notice

